



RRT-3UVPX-NVME-QUAD-M2-C 3U VPX Conduction Cooled Quad NVME M.2 SSD Module

- Capacities up to 16TB (4 x 4TB)
- 3940 MB/S Transfer rates per interface
- Two OpenVPX Fat Pipe (FP) PCIe x4 interfaces
- VITA 65 Slot Profiles:
 - SLT3-PAY-1F1U1S1S1U1U2F1H-14.6.11
 - VPX P1 EP00-EP03
 - VPX P1 EP04-EP07
- VITA 46, 47, 48, 65
- Boot and/or storage disk
- Conduction cooled
- COTS M.2 NVMe SSDs
- Military erase options
- FIPS140-2, FIPS197, TCG Opal options
- Rugged design



THE 3U VPX CONDUCTION COOLED QUAD NVME M.2 SSD MODULE adds 4 SSDs to a VPX system using one 3U VPX slot with COTS M.2 NVMe Solid State Drives (SSDs) providing a wide range of capacity, speed, environmental and security options.

SOSA Aligned to use standard VITA 65 3U Payload Slot Profile with two OpenVPX Fat Pipes (FP) on Expansion plane:

- VPX P1 EP00 - EP03 PCIe x4 Interface1
- VPX P1 EP04 - EP07 PCIe x4 Interface2

SOSA Aligned Slot Profile: SLT3-PAY-1F1U1S1S1U1U2F1H-14.6.11

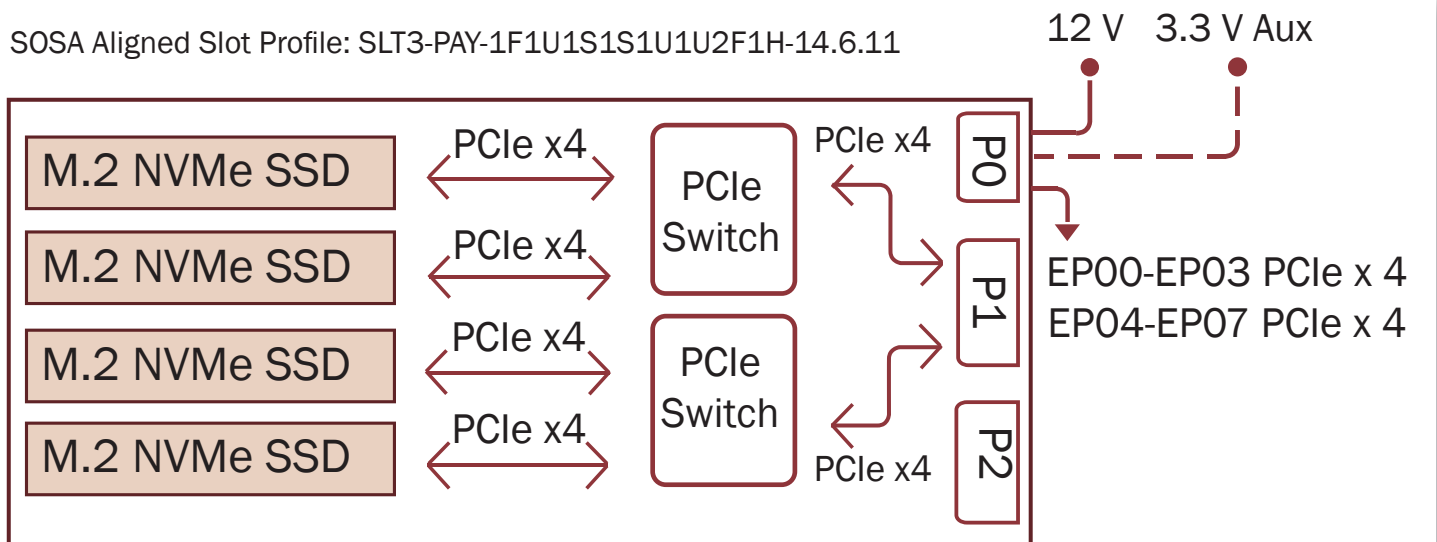

3U VPX Conduction Cooled Quad NVME M.2 SSD Module

RRT-3UVPX-NVMe-QUAD-M2-C-**TLC** - **3.84TBx4** - **UR** - **X** - **FE**

Requirements

NAND Flash Type

TLC	3D NAND Flash
MLC	Multi Level Cell NAND Flash
pSLC	Pseudo Single Level Cell NAND Flash

Capacity

8GB - 4TB	For TLC
500GB - 4TB	For MLC
500GB - 2TB	For pSLC

Options May be left blank

Conformal Coating

UR	Polyurethane
AR	Acrylic

Extended Temperature Range

X	-40°C to 85°C
---	---------------

Security

FE	Fast Erase
SE1	NSA/CSS Manual 9-12 Erase
SE2	RCC-TG IRIG 106-107 Chapter 10 Erase
OPAL	TCG Opal Compliant SSD
FIPS140-2	FIPS 140-2 Compliant SSD
FIPS197	FIPS 197 Compliant SSD

ORDER EXAMPLES

RRT-3UVPX-NVME-QUAD-M2-C-TLC-4TBx4
RRT-3UVPX-NVME-QUAD-M2-C-pSLC-1TBx4-UR-X-SE1



Product Specifications

3U VPX CONDUCTION COOLED CARRIER WITH QUAD M.2 NVME SSD MODULES

PERFORMANCE				
NAND FLASH TYPE	TLC	MLC	pSLC	TLC-X
CAPACITIES ¹	Up to 16TB	Up to 16TB	Up to 4TB	Up to 15.3TB
INTERFACE ²	PCIe Gen 3 x 4	PCIe Gen 2 x 4		PCIe Gen 3 x 4
THROUGHPUT - SUSTAINED	3000MB/S (Gen3)	800 MB/S	1000 MB/S	1500MB/S
RELIABILITY				
MTBF - DRIVE	1 million hours		2 million hours	
MTBF - VPX BOARD ³	3 million hours			
DATA RETENTION	1 year		5 years	1 year
ENDURANCE (100GB) TOTAL BYTES WRITTEN	70 TBW		250 TBW	70 TBW
ENDURANCE RATING ⁴	5 years			
POWER				
VOLTAGE - PAYLOAD SLOT	+12V, +3.3V Aux			
WATTS (IDLE)	15 W			
WATTS (ACTIVE)	30 W			
ENVIRONMENTAL				
OPERATING TEMP., VITA 47 CLASS ⁵	0° C to 55° C, CC1		0° C to 60° C, CC1	See TLC
EXT. OPERATING TEMP., VITA 47 CLASS ⁵	See TLC-X	Not available	-40° C to 70° C, CC2	
STORAGE TEMP.	-40° C to 85° C			
ALTITUDE	10,000 ft. (3,000 meters)		80,000 ft. (24,000 meters)	
RELATIVE HUMIDITY	5% to 95%			
SHOCK, VITA 47 CLASS ⁶	20g, 11 millisecond terminal sawtooth pulse, OS1		40g, 11 millisecond terminal sawtooth pulse, OS2	
VIBRATION, VITA 47 CLASS ⁷	0.04 g ² /Hz, 5 Hz to 100 Hz, V1		0.1 g ² /Hz, 100 Hz to 1000 Hz, V3	
PHYSICAL				
FORM FACTOR	3U VPX			
WEIGHT	16 oz. (454 grams)			
PITCH	0.8"			
NOTES				
<p>(1) Larger capacities available as new COTS U.2 NVMe drives released</p> <p>(2) Interface connected via compatible slot profile SLT3-PAY-1F1U1S1S1U1U2F1H-14.6.11</p> <p>(3) Telcordia SR-332, issue 3, operating temp (40C), electrical stress (50%), environmental factor (1.0)</p> <p>(4) Based on JESD218 standard with 4KB random write workload</p> <p>(5) Thermal qualification per MIL-STD-810F, Method 501 Procedure II, and MIL-STD-810F, Method 502, Procedure II</p> <p>(6) Shock qualification per MIL-STD-810F, Method 516, Procedure I</p> <p>(7) Vibration qualification per MIL-STD-810F, Method 514, Procedure I</p>				



Red Rock Technologies, Inc. reserves the right to modify, change or discontinue specific products within its product line at its own discretion. Red Rock Technologies, Inc. does not assume any liability resulting from the application or use of its products. The information contained herein has been checked and is believed to be entirely accurate; however, no responsibility is assumed for inaccuracies. "Red Rock Technologies" and the mountain logo are registered trademarks of Red Rock Technologies, Inc.
 © Copyright 2024 Red Rock Technologies, Inc.
 All rights reserved. (Rev. 20241105a)