

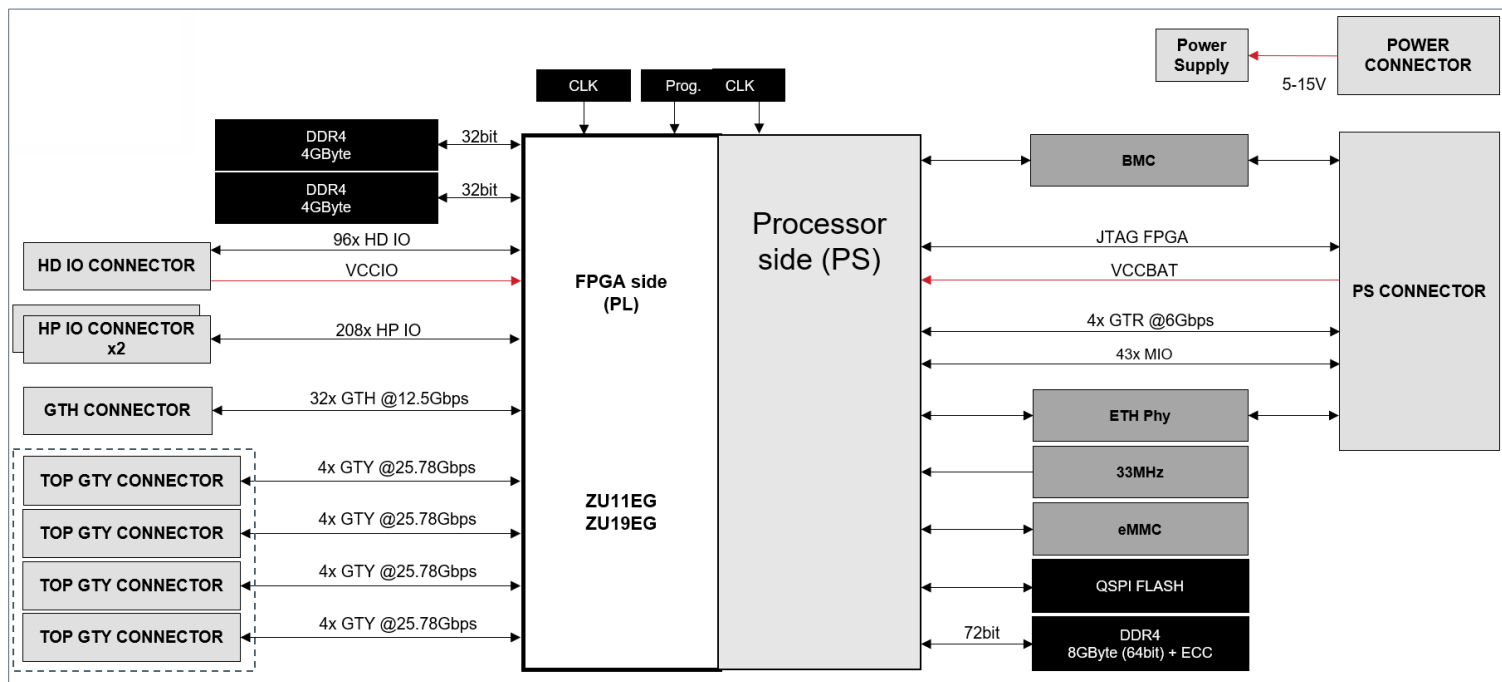

# Zeus Zynq® UltraScale+™ MPSoC System-on-Module

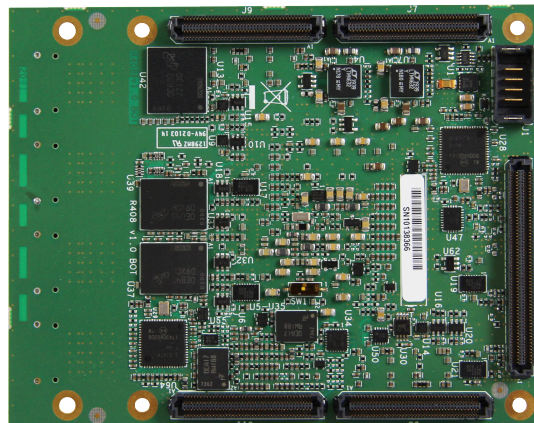
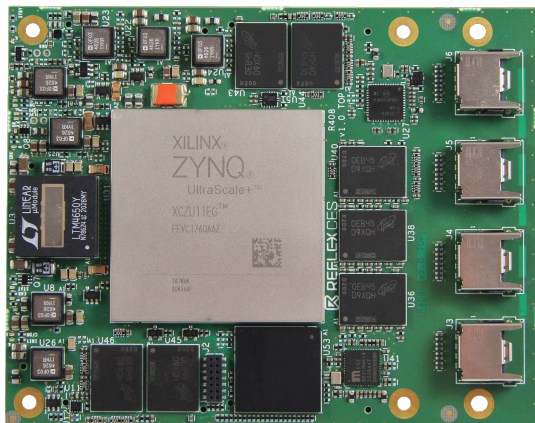

- Zynq® UltraScale+™ MPSoC ZU11EG / ZU19EG
- PCIe Gen2 x4 Root Complex
  - PCIe Gen3 x16 End Point
- Quad-Core ARM Cortex-A53

- 304 SE IOs total (96 LVDS)
- 16 GTY @25.78Gbps (Top side)
- 32 GTH @12.5Gbps (Bot side)
- 3x DDR4 banks, 16GBYTE Total
  - Industrial Temp Grade
  - Long Term Supply

- Software Defined Radio
  - Radar Systems
  - Electronic Warfare
- High Precision Measurement
  - "Customizable"

Features	Zeus Zynq® UltraScale+™ MPSoC	
FPGA SoC	FPGA speed grade 1, Industrial Temp Range Quad-core ARM Cortex-A53 MPCore @1.2GHz Dual-core ARM Cortex-R5 MPCore @500MHz Mali™-400 MP2 @600MHz  <b>Zeus Indus ZU11EG : XCZU11EG-1FFVC1760I device</b> Programmable Logic 653 KLC Total Block RAM 21.1MB, UltraRAM 22.5Mb, 2928 DSP Slices <b>Zeus Indus ZU19EG : XCZU19EG-1FFVC1760I device</b> Programmable Logic 1143 KLC Total Block RAM 34.6MB, UltraRAM 36.0Mb, 1968 DSP Slices	
DDR4 Memory	PL= 2 banks 4GByte each @2400MT/s, x32bit	
	PS= 1 bank 8GByte @2400 MT/s, x64bit + x8bit ECC	
PS Communication & Networking	10/100/1000 Base-T Ethernet RGMII 43x MIO configurable for interface like: NAND flash, eMMC or SD card, ETH RGMII, USB, SPI, I2C, UART, GPIO	
Top Connectors	High Speed Accelerate connectors (GTY)	4x 4 serial transceivers channel (RX and TX) @25.78Gbps (Existing cable adapter to QSFP+ and SFP+ connectors)
Bottom Connectors	Processor (PS) Mezzanine connector	4x serial transceivers channel (RX and TX) @6Gbps PCIe Gen2 x4 Root Complex capable 43x MIO
	GTH Mezzanine connector	32x serial transceivers channel (RX and TX) @12.5Gbps PCIe Gen3 x16 End Point capable
	HP Mezzanine connectors	208x HP I/O high speed up to 1260 Mb/s, designed for high-speed chip-to-chip interfaces with voltages up to 1.8V 96x LVDS capability
	HD Mezzanine connector	96x HD I/O low speed up to 250 Mb/s, designed to support low-speed interfaces with voltages 3.3V, 2.5V, 1.8V, 1.2V
FPGA Configuration	JTAG available on Processor (PS) Mezzanine connector	
	Quad SPI 1Gbit NOR Flash for FPGA, remote upgrade and failsafe configuration	
Software Configuration	128GByte NAND Flash eMMC (Stores U-Boot, Linux Kernel, and RootFS)	
Mechanical & Environmental Specification	Module rugged for shocks and high vibration IEC/EN61000 (EMI immunity), EN61000 + EN55032 (EMI emission), EN60068 (Vibration: sinusoidal, 10Hz - 2KHz, +/- 0.15mm, 2g ; Shock: half-sinusoidal, 11ms, 15g) 5-15V Power Input Industrial temperature grade -40°C to +85°C Conformal coating (option on request)	
Power & Dissipation	<b>Zeus Indus ZU11EG:</b> 70W max, active heatsink (heat spreader + heatsink + fan) <b>Zeus Indus ZU19EG:</b> under definition	
Board Management Controller	Communication with Carrier board: I2C, UART, SMBus Communication with FPGA : 1x UART to PL, 1x UART to PS Monitoring : Current, voltages, temperature, ID information Programming : Clock, QSPI FPGA, QSPI BMC Control: Power, temperature protection, Fans	
Module dimensions	107mm x 85mm (4 x 3.4 inches) / 12mm thickness (38.6mm with active heatsink and heat spreader)	
Deliverables	<ul style="list-style-type: none"> <li>• Zeus Zynq® UltraScale+™ MPSoC module</li> <li>• Active heatsink with heat spreader</li> <li>• Power supply and cables (US, UK, EU, JP), micro-USB cable</li> <li>• Board Support Package (to download from our online technical support):               <ul style="list-style-type: none"> <li>• Starter Guide, Module and carrier board Reference Manuals</li> <li>• HDL Test Designs by interface (Vivado 2020.2 version)</li> <li>• 100G Ethernet MAC HDL test design</li> <li>• Linux Kernel &amp; Linaro optimized distribution, U-boot bootloader, Test scripts</li> <li>• Mechanical drawings, assembly files</li> <li>• Interconnect pinout file</li> <li>• Carrier board schematics, Carrier board Design Guide</li> <li>• On request: 3D step files on the module and its carrier board, Carrier board gerber files, carrier board BOM &amp; PCB specification, S-parameters</li> </ul> </li> <li>• 1-year technical support</li> <li>• 1-year warranty</li> <li>• Online support at <a href="http://support.reflexces.com">support.reflexces.com</a></li> </ul>	
Ordering Information	<b>Zeus Indus ZU11EG:</b> RXCZUP11EGPF42-SOM011 <b>Zeus Indus ZU19EG:</b> RXCZUP19EGPF42-SOM011 – available July 2023	

## Related products

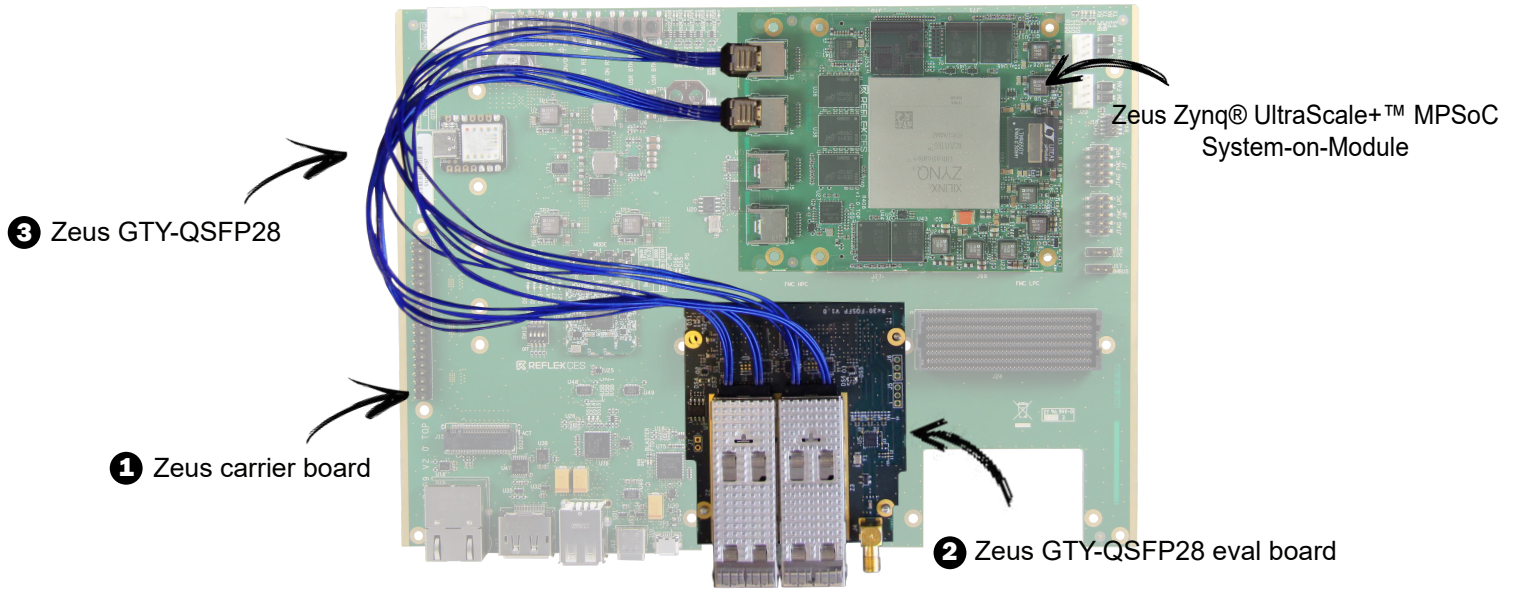

### 1 Zeus carrier board

- The Zeus Carrier board is sold separately
- Ordering information: RXCZUP-CBD0SA

Dimensions: 170mm x 233.35mm

### 2 Zeus GTY-QSFP28 eval board

- The Zeus GTY-QSFP28 eval board is sold separately
- Compatible with the Zeus carrier board
- 2x Zeus GTY-QSFP28 cables are included in the Zeus GTY-QSFP28 eval board
- Ordering information: Zeus GTY-QSFP28 eval board

#### Connectors

- 2x QSFP28 (up to 100Gbps per connector)
- 2x Zeus GTY-QSFP28 cables with ARC6 connectors, 12 inches length
- 1x Clock generator
  - 3 outputs towards FMC connector (Clk0, Clk1, GBTCLK0)
  - 3 inputs (SMA connector, 25Mhz local Quartz, Clk2\_Bidir from FMC)

Misc: 1x E2PROM

FMC dimensions: 69mm x 72.3mm

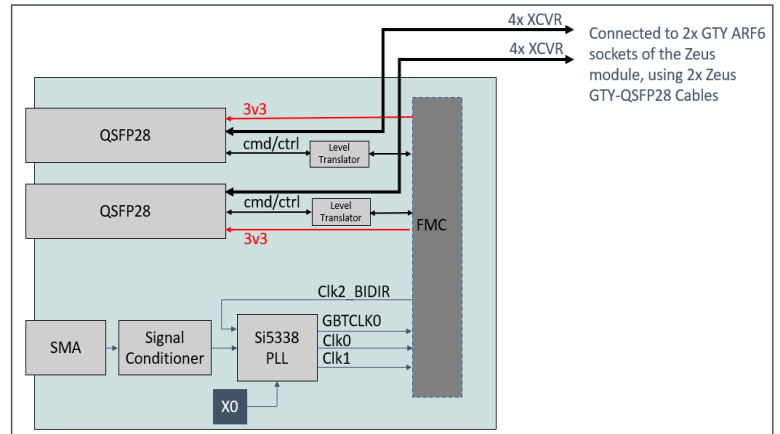

### 3 Zeus GTY-QSFP28 Cable

- 2x Zeus GTY-QSFP28 cables are included in the Zeus GTY-QSFP28 eval board
- The Zeus GTY-QSFP28 cable is sold separately with an MOQ (15)
- To be used for Customer custom carrier board
- Ordering information: Zeus GTY-QSFP28 Cable

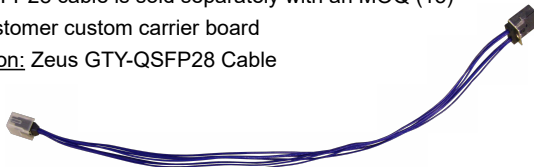

- 12 inches ARC6 custom cable
- Uses the Samtec Flyover® Technology
- Connects GTY connector to QSFP-28 connector